

Rotary Hammer

Model: *XP-R26A*

HANDLING INSTRUCTIONS



Before using this XINPU rotary hammer, please carefully read though these **HANDLING INSTRUCTIONS**. Ensure that you know how the machine works, and how it should be operated. Maintain the machine in accordance with the instructions, and make certain that the machine work correctly, please store this instriation and other enclosed documents with the machine together.



Zhejiang Xinpu Industrial & Commercial Co., Ltd.

106, No. 330 National Road, Huajie Industrial Zone, Yongkang City, Zhejiang 321300, P. R. China

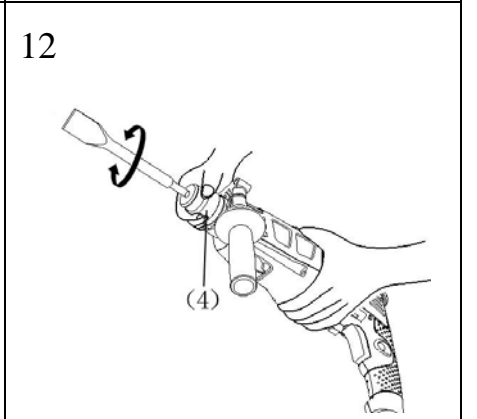
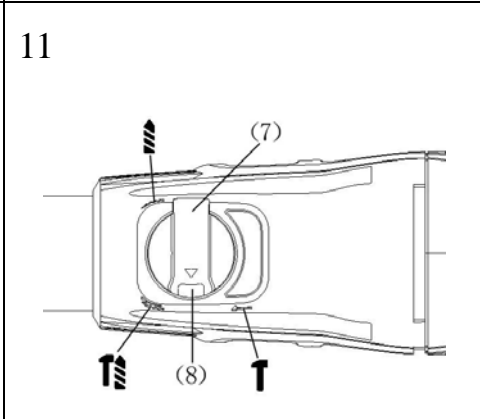
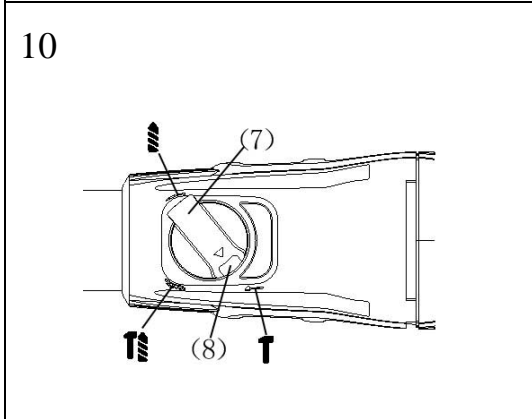
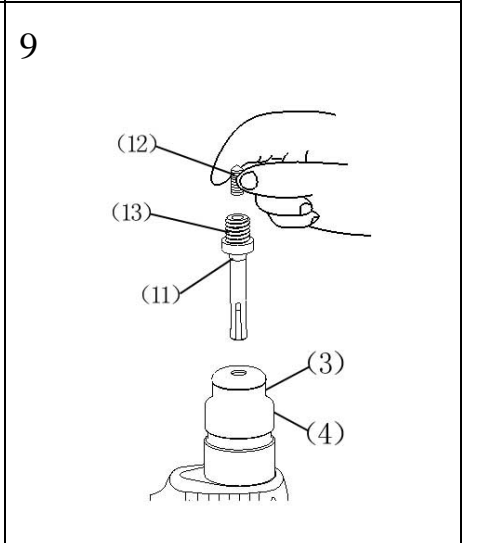
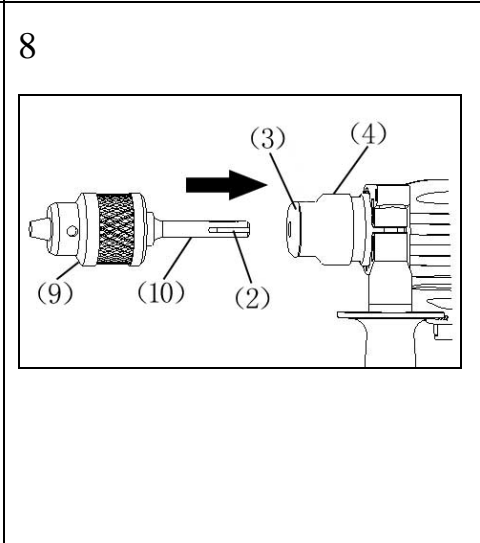
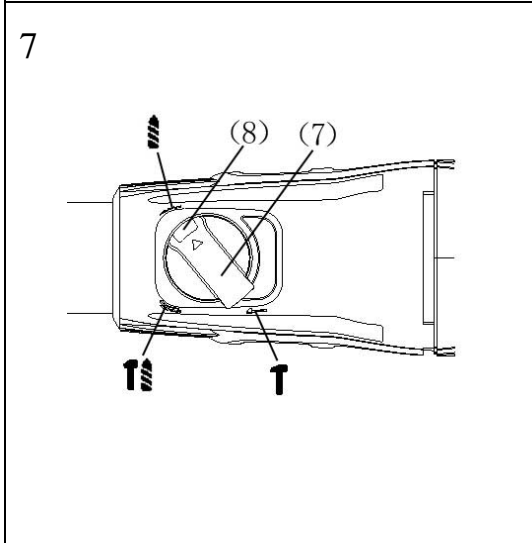
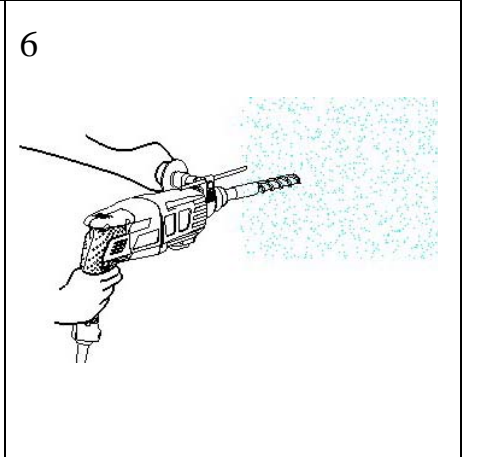
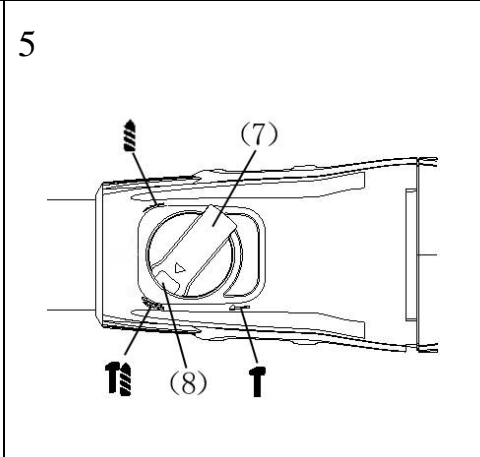
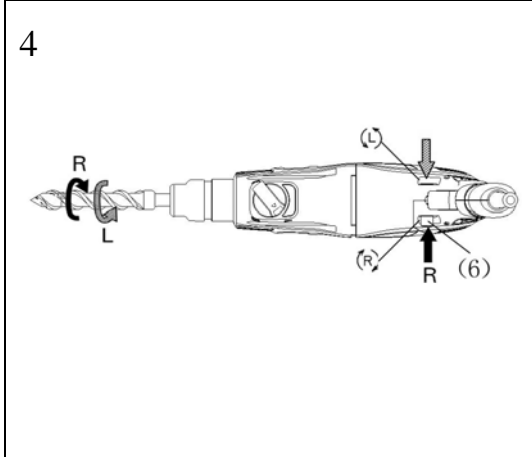
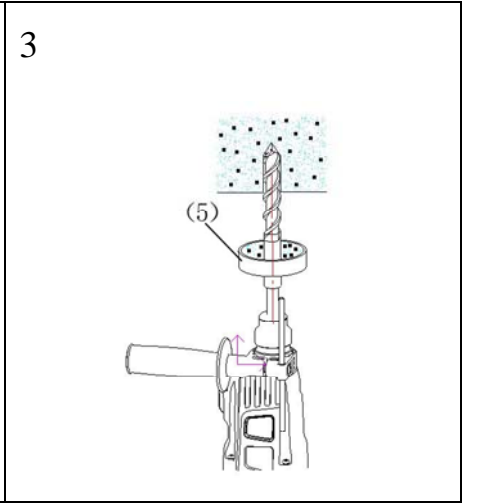
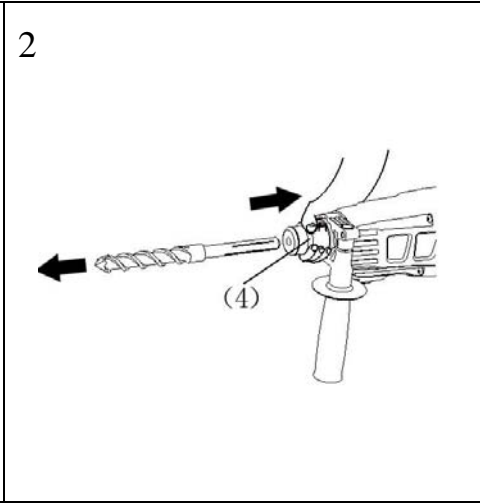
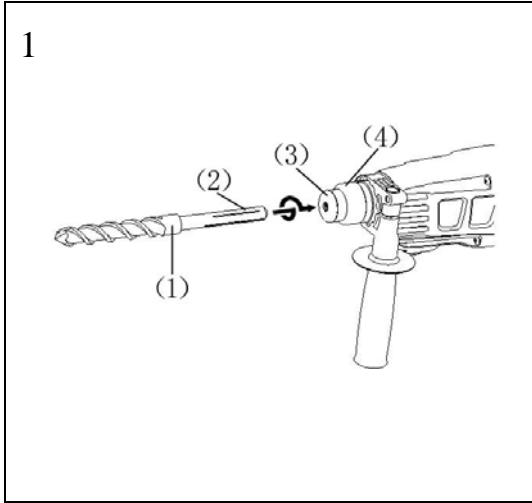

13

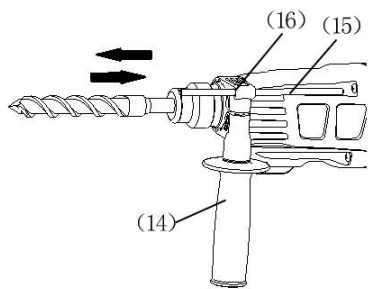

14

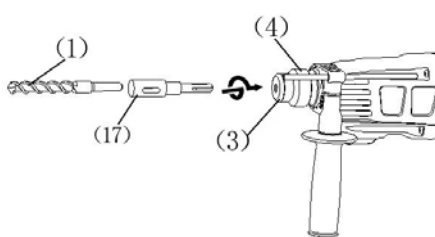

15

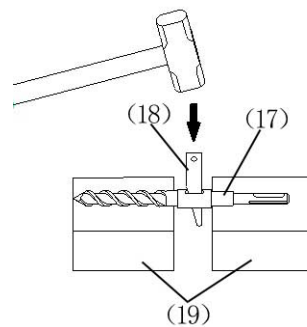

16

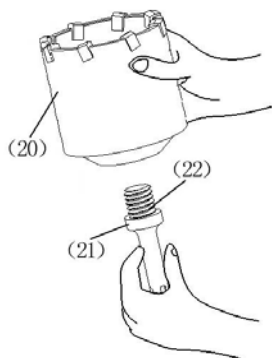

17

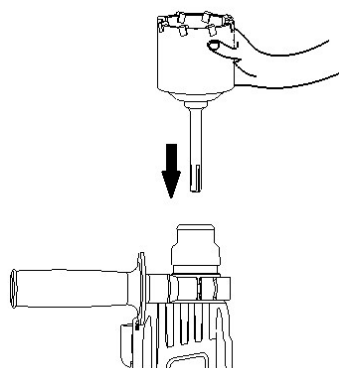

18

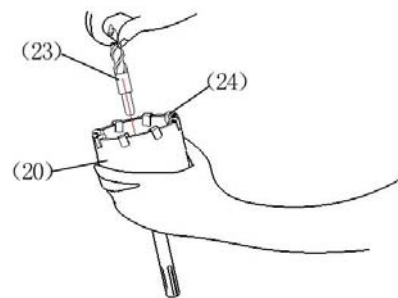

19

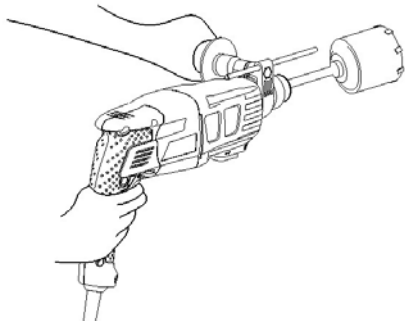

20

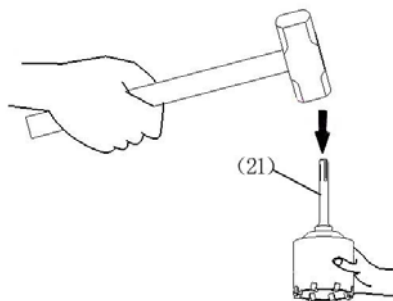

22

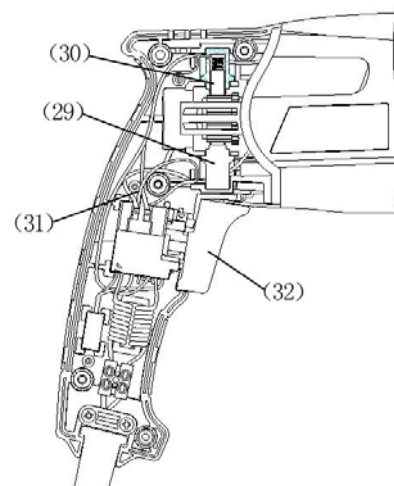

21

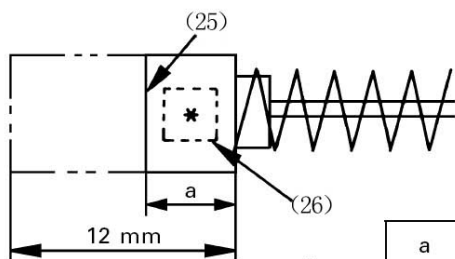

	a	(26)
(27)	5mm	41
(28)	-	72

(1)	Drill bit
(2)	Part of SDS-plus shank
(3)	Turn Staff Armor
(4)	Flex Sheath
(5)	Dust cup
(6)	Stir Block
(7)	Function Knob
(8)	Push button
(9)	Drill chuck
(10)	Drill chuck shank
(11)	Drill chuck shank (D)
(12)	Driver bit
(13)	Socket
(14)	Side handle
(15)	Staff gauge
(16)	Mounting hole
(17)	Tape shank bit
(18)	Cotter
(19)	Rest
(20)	Core bit
(21)	Core bit shank
(22)	Thread
(23)	Drill bit
(24)	Core bit tip
(25)	Wear limit
(26)	No. of carbon brush
(27)	Usual carbon brush
(28)	Auto-stop carbon brush
(29)	Brush holder
(30)	Carbon brush
(31)	Internal wiring
(32)	Switch

GENERAL SAFETY RULES

WARNING

Read all safety warnings and all instructions. Failure to follow all warnings and instructions may result in electric shock, fire and/or serious injury.

Save all warnings and instructions for future reference

The term “power tool” in the warnings refer to your mains operated (corded) power tool or battery operated (cordless) power tool.

1) Work area

- a) **Keep work area clean and well lit.** *Cluttered and dark areas invite accidents.*
- b) **Do not operate power tools in explosive atmospheres, such as in the presence of flammable liquids, gases or dust.** *Power tools create sparks which may ignite the dust or fumes.*
- c) **Keep children and bystanders away while operating a power tool.** *Distractions can cause you to lose control.*

2) Electrical safety

- a) **Power tool plugs must match the outlet. Never modify the plug in any way. Do not use any adapter plugs with earthed (grounded) power tools.** *Unmodified plugs and matching outlets will reduce risk of electric shock.*
- b) **Avoid body contact with earthed or grounded surfaces such as pipes, radiators, ranges and refrigerators.** *There is an increased risk of electric shock if your body is earthed or grounded.*
- c) **Do not expose power tools to rain or wet conditions.** *Water entering a power tool will increase the risk of electric shock.*
- d) **Do not abuse the cord. Never use the cord for carrying, pulling or unplugging the power tool. Keep cord away from heat, oil, sharp edges or moving parts.** *Damaged or entangled cords increase the risk of electric shock.*
- e) **When operating a power tool outdoors, use an extension cord suitable for outdoor use.** *Use of a cord suitable for outdoor use reduces the risk of electric shock.*
- f) **If operating a power tools in a damp location is unavoidable, use a residual current device (RCD) protected supply.** *Use of an RCD reduces the risk of electric shock.*

3) Personal safety

- a) **Stay alert, watch what you are doing and use common sense when operating a power tool. Do not use a power tool while you are tired or under the influence of drugs, alcohol or medication.** *A moment of inattention while operating power tools may result in serious personal injury.*
- b) **Use safety equipment. Always wear eye protection.** *Safety equipment such as dust mask, non-skid safety shoes, hard hat, or hearing protection used for appropriate conditions will reduce personal injuries.*
- c) **Avoid accidental starting. Ensure the switch is in the off position before plugging in.** *Carrying power tools with your finger on the switch or plugging in power tools that have the switch on invites accidents.*
- d) **Remove any adjusting key or wrench before turning the power tool on.** *A wrench or a key left attached to a rotating part of the power tool may result in personal injury.*
- e) **Do not overreach. Keep proper footing and balance at all times.** *This enables better control of the power tool in unexpected situations.*
- f) **Dress properly. Do not wear loose clothing or jewellery. Keep your hair, clothing and gloves away from moving parts.** *Loose clothes, jewellery or long hair can be caught in moving parts.*
- g) **If devices are provided for the connection of dust extraction and collection facilities, ensure these are connected and properly used.** *Use of these devices can reduce dust related hazards.*

4) Power tool use and care

- a) **Do not force the power tool. Use the correct power tool for your application.** *The correct power tool will do the job better and safer at the rate for which it was designed.*
- b) **Do not use the power tool if the switch does not turn it on and off.** *Any power tool that cannot be controlled with the switch is dangerous and must be repaired.*
- c) **Disconnect the plug from the power source before making any adjustments, changing accessories, or storing power tools.** *Such preventive safety measures reduce the risk of starting the power tool accidentally.*
- d) **Store idle power tools out of the reach of children and do not allow persons unfamiliar with the power tool or these instructions to operate the power tool.** *Power tools are dangerous in the hands of untrained users.*
- e) **Maintain power tools. Check for misalignment or binding of moving parts, breakage of parts and any other condition that may affect the power tools operation. If damaged, have the power tool repaired before use.** *Many accidents are caused by poorly maintained power tools.*
- f) **Keep cutting tools sharp and clean.** *Properly maintained cutting tools with sharp cutting edges are less likely to bind and are easier to control;*

- g) **Use the power tool, accessories and tool bits etc., in accordance with these instructions and in the manner intended for the particular type of power tool, taking into account the working conditions and the work to be performed.** *Use of the power tool for operations different from intended could result in a hazardous situation.*

5) Service

- a) **Have your power tool serviced by a qualified repair person using only identical replacement parts.** *This will ensure that the safety of the power tool is maintained.*

Special Warning for Electric hammer

- Wear ear protection. Exposure to noise can cause hearing loss.
- Use auxiliary handle with the tool. Loss of control can cause personal injury.

Symbol



“WARNING – To reduce the risk of injury, user must read instruction manual”



Waste electrical products should not be disposed of with house hold waste, Please recycle where facilities exist. Check with your local Authority or retailer for recycling advice.

PRECAUTION

Keep children and infirm persons away.

When not in use, tools should be stored out of reach of children and infirm persons.

PRECAUTIONS ON USING POTARY HAMMER

1. Wear ear protections
Exposure to noise can cause hearing loss.
2. Do not touch the bit during or immediately after operation. The bit becomes very hot during operation and could cause serious burns.
3. Before starting to break, chip or drill into a wall, floor or ceiling, thoroughly confirm that such items as electric cables or conduits are not buried inside.
4. Use auxiliary handles supplied with the tool.
Loss of control can cause personal injury.
5. Always hold the body main handle and side handle of the power tool firmly. Otherwise the counterforce produced may result in inaccurate and even dangerous operation.
6. Wear a dust mask
Do not inhale the harmful dusts generated in drilling or chiseling operation. The dust can endanger the health of yourself and bystanders.

SPECIFICATIONS

Voltage	220-240V~
Power Input	800W
No-load speed	0-1200/min
Full-load impact rate	0-4800/min
Capacity: concrete	3.4-24mm
steel	13mm
wood	32mm
Weight (without cord and side handle)	2.7kg

*Be sure to check the nameplate on product as it is subject to change by areas.

STANDARD ACCESSORIES

- (1) Plastic case-----1
- (2) Dual Screw Driver -----1
- (3) Staff Gauge -----1

Standard accessories are subject to change without notice.

OPTIONAL ACCESSORIES (sold separately)

1. Drilling anchor holes (rotation + hammering)

- Drill bit (Slender shaft)

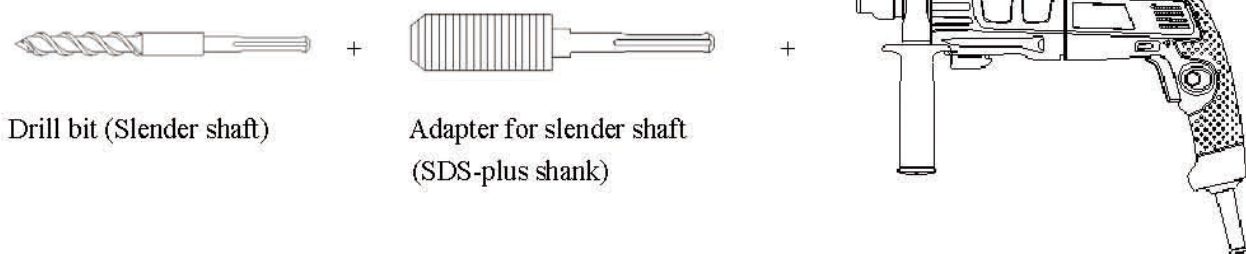

Drill bit (Slender shaft)

Adapter for slender shaft
(SDS-plus shank)

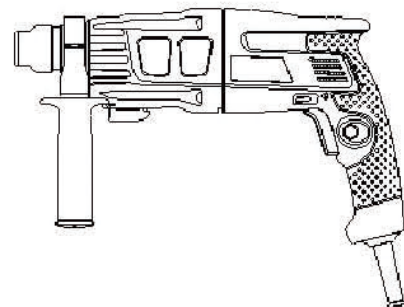

Drill bit (slender shaft)		
Outer diameter	Effective length	Overall length
3.4mm	45mm	90mm
3.5mm		

- Drill bit (Taper shank) and taper shank bit

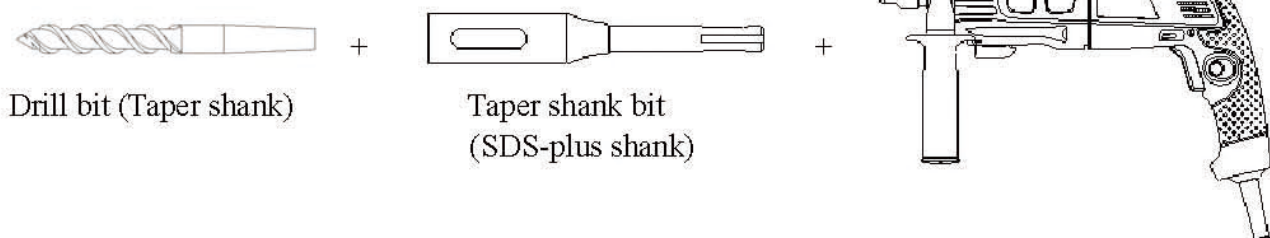

Drill bit (Taper shank)

Taper shank bit
(SDS-plus shank)

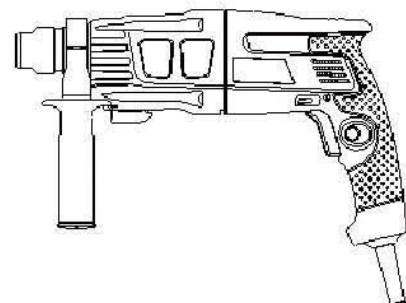

Cotter

Outer diameter
11.0mm
12.3mm
12.7mm
14.3mm
14.5mm
17.5mm
21.5mm

Taper mode	APPLICABLE DRILL BIT	
Morse taper(No.1)	Drill bit (taper shank)	11.0~17.5mm
Morse taper(No.2)	Drill bit (taper shank)	21.5mm
A-taper	Taper shank bit formed A-taper or B-taper is provided as an optional accessory, but the drill bit for it is not provided.	
B-taper		

○ 13mm Rotary Hammer drill chuck

For drilling operations when using a drill bit with a rotary hammer.

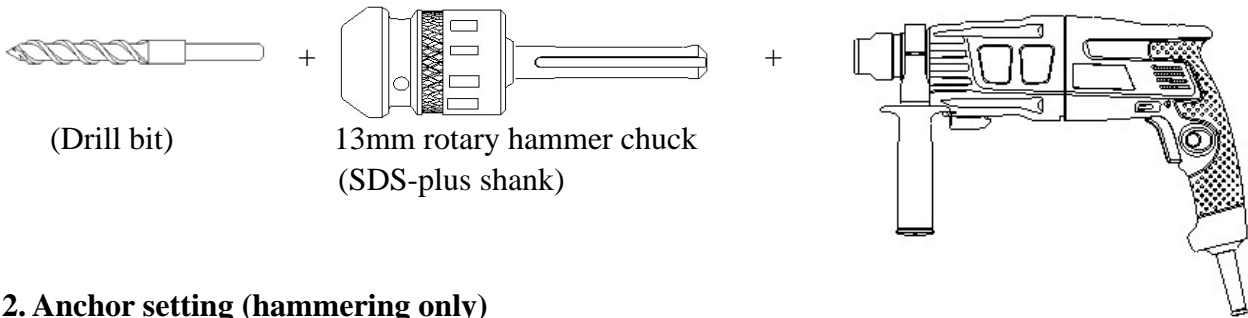

2. Anchor setting (hammering only)

○ Anchor setting adapter (for rotary hammer)

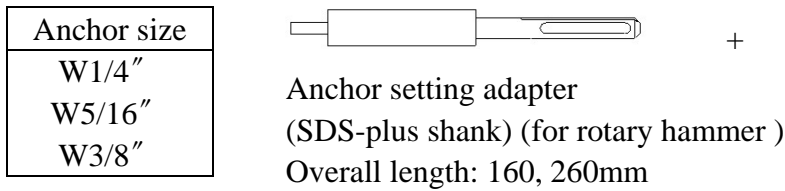

○ Anchor setting adapter (for manual hammer)

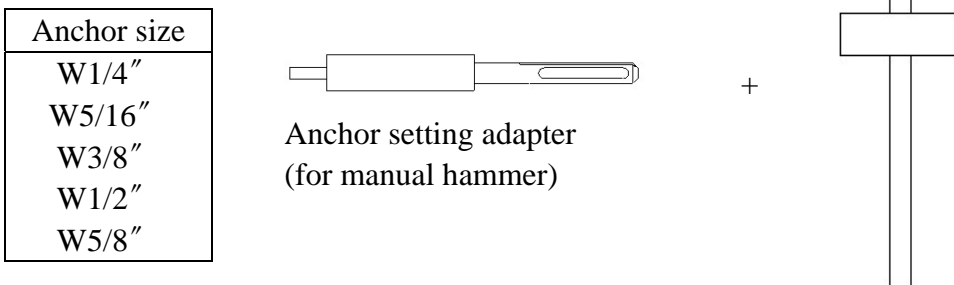

3. Large hole boring (rotation + hammering)

○ Drill bit, core bit and core bit shank

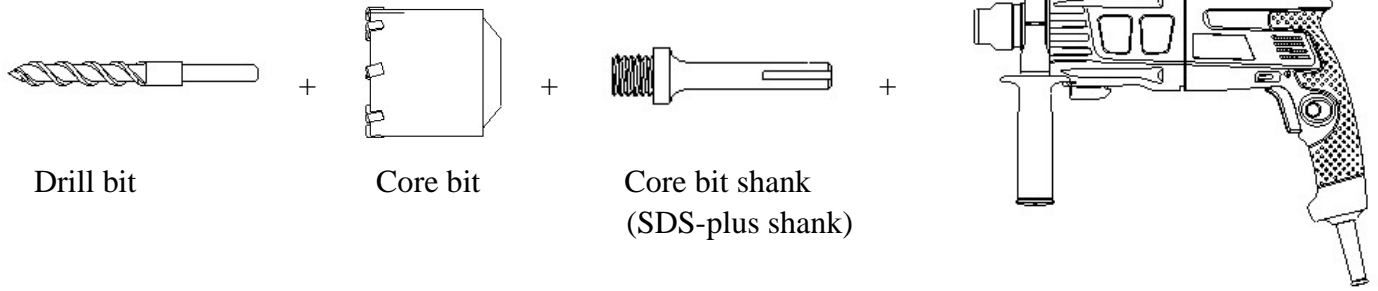

Drill bit	Core bit (outer diameter)		Core bit shank
Φ8x110mm	(A)	25mm	Core bit shank(A)
		29mm	
		32mm	
		35mm	
	38mm		
(B)	45mm	Core bit shank(B)	
50mm			

4. Demolishing operation (hammering only)

Bull point (Round type) (SDS-plus shank)

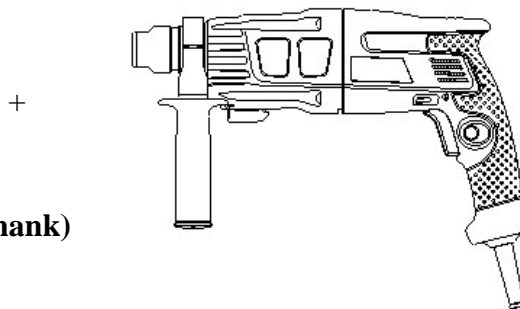

Bull point (Square type) (SDS-plus shank)

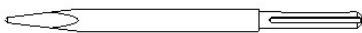

5. Groove digging and edging (hammering only)

Cold chisel (SDS-plus shank)

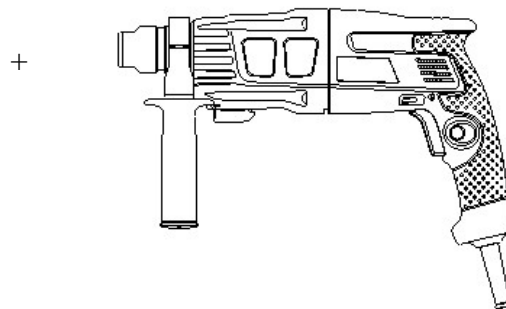

Cutter (SDS-plus shank)



6. Grooving (Hammering only)

Grooving chisel (SDS-plus shank)

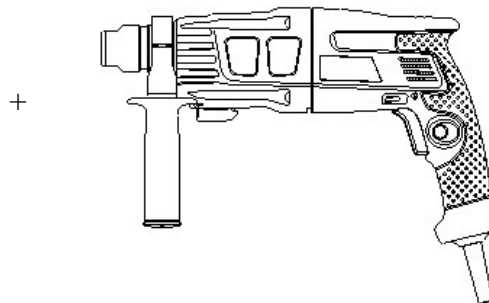

7. Bolt placing operation with Chemical Anchor (rotation + hammering)



+

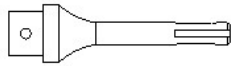

+

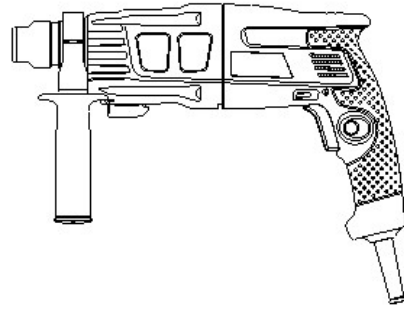

(Standard socket
On the market)

(SDS-plus shank)
12.7mm Chemical Anchor Adapter
19mm Chemical Anchor Adapter

8. Drilling holes and driving screws (rotation only)

○ Drill chuck, Drill chuck shank(G), special screw and Drill chuck key

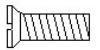

+

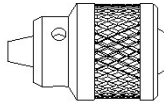

+

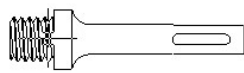

+

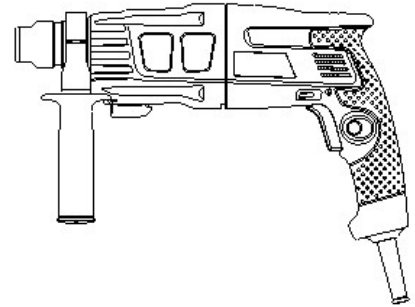

Special screw

Drill chuck (13VLRB-D)

Drill chuck shank (G)
(SDS-plus shank)

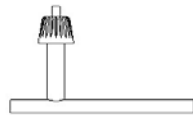

Drill chuck key

9. Drilling holes (rotation only)

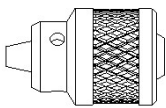

+

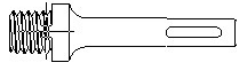

+

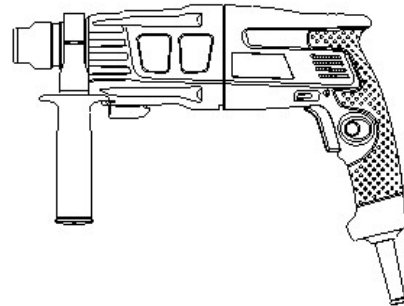

Drill chuck (13VLRB-D)

Drill chuck shank (G)
(SDS-plus shank)

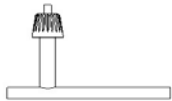

Drill chuck key

13mm Drill chuck ass'y (includes Drill chuck key) and chuck (for drilling in steel or wood).

10. Driving Screws (rotation only)



+

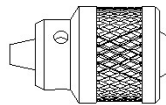

+

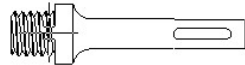

+

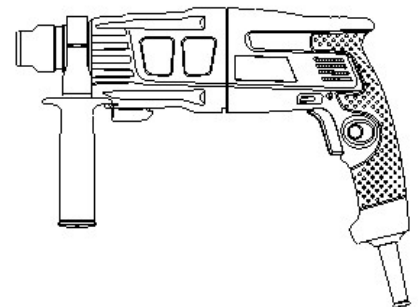

Screw drive

Drill chuck (13VLRB-D)

Drill chuck shank (D)
(SDS-plus shank)

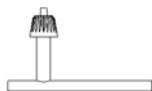

Drill chuck key

11. Dust cup



12. Hammer grease (30g)



Optional accessories are subject to change without notice.

APPLICATIONS

Rotation and hammering function

- Drilling anchor holes
- Drilling holes in concrete
- Drilling holes in tile

Rotation only function

- Drilling in steel or wood
(with optional accessories)
- Tightening machine screws, wood screws
(with optional accessories)

Hammering only function

- Light-duty chiseling of concrete, groove digging and edging.

PRIOR TO OPERATION

1. Power source

Ensure that the power source to be utilized conforms to the power requirements specified on the product nameplate.

2. Power switch

Ensure that the power switch is in the OFF position. If the plug is connected to a power receptacle while the power switch is in the ON position, the power tool will start operating immediately, which could cause a serious accident.

3. Extension cord

When the work area is removed from the power source, use an extension cord of sufficient thickness and rated capacity. The extension cord should be kept as short as practicable.

4. Mounting the drill bit (Fig.1)

CAUTION:

To prevent accidents, make sure to turn the switch off and disconnect the plug from the receptacle.

NOTE

When using tools such as drill bits, etc., make sure to use the genuine parts designated by our company.

- (1) Clean the shank portion of the drill bit.
- (2) Insert the drill bit in a twisting manner into the tool holder until it latches itself (**Fig.1**)
- (3) Check the latching by pulling on the drill bit.
- (4) To remove the drill bit, fully pull the flex sheath in the direction of the arrow and pull out the drill bit (**Fig.2**).

5. Installation of dust cup (Optional accessories) (Fig.3)

When using a rotary hammer or upward drilling operations attach a dust cup to collect dust or particles for easy operation.

- Installing the dust cup

Use the dust cup by attaching to the drill bit as shown in **Fig.3**

When using a bit which has big diameter, enlarge the center hole of the dust cup with this rotary hammer.

CAUTION

- The dust cup are for exclusive use of concrete drilling work. Do not use them for wood or metal drilling work.
- Dump particles after every two or three holes when drilling.

6. Selecting the driver bit

Screw heads or bits will be damaged unless a bit appropriate for the screw diameter is employed to drive in the screws.

7. Confirm the direction of bit rotation (Fig.4)

The bit rotates clockwise (viewed from the rear side) by pushing the R-side of the stir block. The L-side of the stir block is pushed to turn the bit counterclockwise.

HOW TO USE

CAUTION:

To prevent accidents, make sure to turn the switch off and disconnect the plug from the receptacle when the drill bits and other various parts are installed or removed. The power switch should also be turned off during a work break and after work.

1. Switch operation

The rotation speed of the drill bit can be controlled steplessly by varying the amount that the trigger switch is pulled. Speed is low when the trigger switch is pulled slightly and increases as the switch is pulled more. Continuous operation may be attained by pulling the trigger switch and depressing the stopper. To turn the switch OFF, pull the trigger switch again to disengage the stopper, and release the trigger switch to its original position.

However, the switch trigger can only be pulled in halfway during reverse and rotates at half the speed of forward operation.

The switch stopper is unusable during reverse.

2. Rotation + hammering

This rotary hammer can be set to rotation and hammering mode by pressing the push button and turning the function knob to the **T** mark (Fig.5).

- (1) Mount the drill bit.
- (2) Pull the trigger switch after applying the drill bit tip to the drilling position (Fig.6).
- (3) Pushing the rotary hammer forcibly is not necessary at all. Pushing slightly so that drill dust comes out gradually is sufficient.

CAUTION:

When the drill bit touches construction iron bar, the bit will stop immediately and the rotary hammer will react to revolve. Therefore grip the side handle and Main Handle tightly as shown in Fig.6.

3. Rotation only

This rotary hammer can be set to rotation only mode by pressing the push button and turning the function knob to the **R** mark (Fig.7).

To drill wood or metal material using the drill chuck and drill chuck shank (optional accessories), proceed as follows.

Installing drill chuck and drill chuck shank (Fig.8).

- (1) Attach the drill chuck to the drill chuck shank.
- (2) The part of the SDS-plus shank is the same as the drill bit. Therefore, refer to the item of "Mounting the drill bit" for attaching it.

CAUTION:

- Application of force more than necessary will not only expedite the work, but will deteriorate the tip edge of the drill bit and reduce the service life of the rotary hammer in addition.
- Drill bits may snap off while withdrawing the rotary hammer from the drilled hole. For withdrawing, it is important to use a pushing motion.

- Do not attempt to drill anchor holes or holes in concrete with the machine set in the rotation only function.
- Do not attempt to use the rotary hammer in the rotation and hammering function with the drill chuck and drill chuck shank attached. This would seriously shorten the service life of every component of the machine.

4. When driving machine screws (Fig.9)

First, insert the bit into the socket in the end of drill chuck shank.

Next, mount drill chuck shank on the main unit using procedures described in 4(1), (2), (3), put the tip of the bit in the slots in the head of the screw, grasp the main unit and tighten the screw.

CAUTION:

- Exercise care not to excessively prolong driving time, otherwise, the screws may be damaged by excessive force.
- Apply the rotary hammer perpendicularly to the screw head when driving the screw; otherwise, the screw head or bit will be damaged. Or driving force will not be fully transferred to the screw.
- Do not attempt to use the rotary hammer in the rotation and hammering function with the drill chuck shank and bit attached.

5. When driving wood screws (Fig.9)

(1) Selecting a suitable driver bit

Employ cross-recessed screws, if possible, since the driver bit easily slips off the heads of slotted-head screws.

(2) Driving in wood screws

- Prior to driving in wood screws, make pilot holes suitable for them in the wooden board. Apply the bit to the screw head grooves and gently drive the screws into the holes.
- After rotating the rotary hammer at low speed for a while until the wood screw is partly driven into the wood, squeeze the trigger more strongly to obtain the optimum driving force.

CAUTION:

Exercise care in preparing a pilot hole suitable for the wood screw taking the hardness of the wood into consideration. Should the hole be excessively small or shallow, requiring much power to driver the screw into it, the thread of the wood screw may sometimes be damaged.

6. Hammering only

This rotary hammer can be set to hammering only mode by pressing the push button and turning the function knob to the **T** mark. **(Fig.10)**

(1) Mount the bull point or cold chisel.

(2) Press the push button and set the function knob to middle of **T mark and **T** mark.. **(Fig.11)****

The rotation is released, turn the flex sheath and adjust the cold chisel to desired position. **(Fig.12)**

(3) Turn the function knob to **T mark. **(Fig.10)****

Then bull point or cold chisel is locked.

7. Using Staff Gauge (Fig.13)

- (1) Loosen the knob on the side handle, and insert the staff gauge into the mounting hole on the side handle.
- (2) Adjust the staff gauge position according to the depth of the hole and tighten the knob securely.

8. How to use the drill bit (taper shank) and the taper shank bit adapter

(1) Mount the taper shank bit to the rotary hammer **(Fig.14).**

(2) Mount the drill bit (taper shank) to the taper shank bit **(Fig.14).**

(3) Turn the switch ON, and drill a hole in prescribed depth.

(4) To remove the drill bit (taper shank), insert the cotter into the slot of the taper shank bit and strike the head of the cotter with a hammer supporting on a rests **(Fig.15).**

HOW TO USE THE CORE BIT (FOR LIGHT LOAD)

When boring penetrating large holes use the core bit (for light loads). At that time use with the drill bit and the core bit shank provided as optional accessories.

1. Mounting

CAUTION:

Be sure to turn power OFF and disconnect the plug from the receptacle.

(1) Mount the core bit to the core bit shank. **(Fig.16)**

Lubricate the thread of the core bit shank to facilitate disassembly.

(2) Mount the core bit to the rotary hammer **(Fig.17)**

(3) Engage the drill bit with the core bit, and turn the guide plate to the left or the right so that it does not fall even if it faces downward. **(Fig.18)**

2. Hoe to bore (Fig.19)

(1) Connect the plug to the power source.

(2) Push it lightly to the wall or the floor straight.

Connect the core bit tip flush to the surface and start operating.

(3) When boring about 5mm in depth the position of the hole will be established. Bore after that removing the drill bit from core bit.

(4) Application of excessive force will not only expedite the work, but will deteriorate the tip edge of the drill bit, resulting in reduced service life of the hammer drill.

CAUTION:

When removing the drill bit, turn OFF the switch and disconnect the plug from the receptacle.

3. Dismounting (Fig.20)

Remove the core bit shank from the rotary hammer and strike the head of the core bit shank strongly two or three times with a hammer holding the core bit, then the thread becomes loose and the core bit can be removed.

LUBRICATION

Low viscosity grease is applied to this rotary hammer so that it can be used for a long period without replacing the grease. Please contact the nearest service center for grease replacement when any grease is leaking from loosened screw.

Further use of the rotary hammer with lock off grease will cause the machine to seize up reduce the service life.

CAUTION:

A special grease is used with this machine, therefore, the normal performance of the machine may be badly affected by use of other grease. Please be sure to let one of our service agents undertake replacement of the grease.

MAINTENANCE AND INSPECTION

1. Inspecting the drill bits

Since use of a dull tool will cause motor malfunctioning and degraded efficiency, replace the drill bit with new ones or sharpen them without delay when abrasion is noted.

2. Inspecting the mounting screws

Regularly inspect all mounting screws and ensure that they are properly tightened. Should any of the screws be loose, retighten them immediately. Failure to do so could result in serious hazard.

3. Maintenance of the motor

The motor unit winding is the very “heart” of the power tool. Exercise due care to ensure the winding does not become damaged and/or wet with oil or water.

4. Inspecting the carbon brushes (Fig.21)

The motor employs carbon brushes which are consumable parts. When they become worn to or near “wear limit”, it could result in motor trouble. When an auto-stop carbon brush is equipped, the motor will stop automatically.

At that time, replace both carbon brushes with new ones which have the same carbon brush numbers shown in **Fig.21**

In addition, always keep carbon brushes clean and ensure that they slide freely within the brush holders.

5. Replacing a carbon brush (Fig.22)

○ Disassembling

- (1) Loosen the five screws on the main handle cover, and remove the main handle cove.
- (2) Lift out the brush holder together with the carbon brush, while being very careful not to forcibly pull the lead wires within the brush holder.
- (3) Withdraw the insert piece, and remove the carbon brush from the brush holder.

○ Reassembling

- (1) Place a new carbon brush into the insert piece, and connect the brush terminal to the carbon brush.
- (2) Return the brush holder and other parts to their original positions, as illustrated in **Fig.22**
- (3) Place the lead wire in the specified position. Be very careful not to allow the lead wire to contact the armature or rotating parts of the motor.
- (4) Replace the main handle cover, while being careful to ensure it does not pinch the lead wire, and secure it firmly with the five screws.

CAUTION:

Should the lead wire be pinched by the main handle cover or come in contact with the armature or rotating parts of the motor, a serious danger of electric shock to the operator will be created. Exercise extreme caution in disassembling and reassembling the motor, following the above procedures exactly.

Do not attempt to disassemble any parts other than those necessary to effect replacement of the carbon brush.

6. Service parts list

CAUTION:

Repair, modification and inspection of Xinpu Power Tools must be carried out by a Xinpu Authorized Service Center.

This Parts List will be helpful if presented with the tool to the Xinpu Authorized Service Center when requesting repair or other maintenance.

In the operation and maintenance of power tools, the safety regulations and standards prescribed in each country must be observed.

MODIFICATIONS

Xinpu Power Tools are constantly being improved and modified to incorporate the latest technological advancements.

Accordingly, some parts may be changed without prior notice.

NOTE:

Due to XINPU'S continuing program of research and development, the specifications herein are subject to change without prior notice.

XP-R26A RoTary Hammer Part Chart

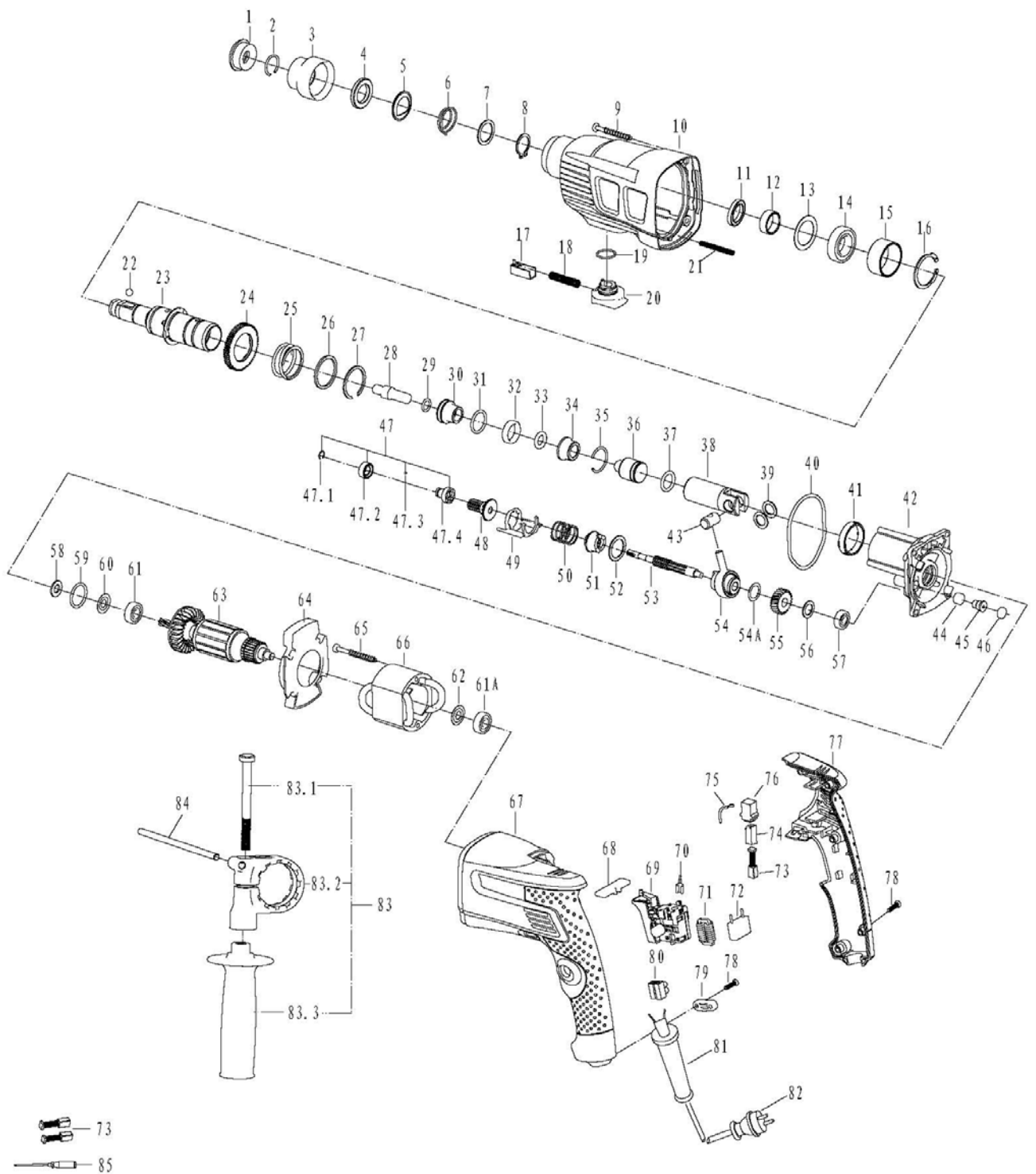

XP-R26A Rotary Hammer parts list

XP-No	Item No.	Part Describe	Quantit y	XP-No	Item No.	Part Describe	Quantit y
88264059	1	Turn Staff Armor	1	88224065	47.1	Steel Wire Block Ring $\Phi 7.4 \times \Phi 0.8$	1
88224050	2	Steel Wire Block Ring $\Phi 18.5 \times \Phi 2$	1	88224066	47.2	Gear Ring Base	1
88264061	3	Flex Sheath	1	88210128	47.3	S $\Phi 2$ Steel ball	16
88224076	4	Ball Platen $\Phi 20.2 \times \Phi 31.9 \times 4.5$	1	88275034	47.4	Gear Ring	1
88224051	5	Disk-type Nog	1	88224067	48	Secondary Pinion	1
88224052	6	Nog Spring	1	88224068	49	Metal Dial Support	1
88224053	7	Washer A $\Phi 20.3 \times \Phi 26.9 \times 1$	1	88224069	50	Clutch Spring B $\Phi 17 \times \Phi 1.2 \times 20$	1
88210124	8	$\Phi 20 \times 1$ Retaining Ring	1	88275035	51	Clutch Block	1
88210130	9	Tapping Screw ST4.8x35	4	88224075	52	Clutch Washer $\Phi 19 \times \Phi 22.5 \times 0.6$	1
88264062	10	Gear Case	1	88224070	53	Middle Shaft	1
88264057	11	Oil Seal Ring $\Phi 34 \times \Phi 24 \times 6$	1	88238004	54	Sway Bearing	1
88224054	12	Steel Ring A $\Phi 20 \times \Phi 23.8 \times 9.5$	1	88224078	54A	Washer $\Phi 8.9 \times \Phi 20 \times 1$	1
88310005	13	Woolen Washer A	1	88224071	55	Stair Gearwheel	1
88238001	14	6904(2RS C2) Ball Bearing	1	88224072	56	Distance Washer $\Phi 6.2 \times \Phi 11.9 \times 1$	1
88224055	15	Steel Ring B $\Phi 33 \times \Phi 37 \times 17.2$	1	88238002	57	626(2RS C2) Ball Bearing	1
88210126	16	$\Phi 37 \times 1.5$ Retaining Ring	1	88310008	58	Woolen Washer D	1
88264063	17	Pushbutton	1	88264052	59	Fluorin O Ring $\Phi 22 \times \Phi 2.4$	1
88224056	18	Pushbutton spring $\Phi 7 \times \Phi 0.8 \times 35$	1	88224073	60	Washer D $\Phi 9.6 \times \Phi 21.8 \times 0.5$	1
88264050	19	Fluorin O Ring $\Phi 17.7 \times \Phi 1.5$	1	88238003	61	608(2RS C3) Ball Bearing	1
88264064	20	Function Knob	1	88238005	61A	608 VV Ball Bearing	1
88224057	21	Spring A $\Phi 4.5 \times \Phi 0.5 \times 42.5$	2	88224018	62	608 Bearing Washer $\Phi 21 \times \Phi 8.4 \times 0.3$	1
88210127	22	S $\Phi 7$ Steel ball	1	88280097	63	Armature	1
88224058	23	Hammer Staff Sheath	1	88264065	64	Fan Guide	1
88224059	24	Secondary Gearwheel	1	88210131	65	Tapping Screw ST4.2x50	2
88224060	25	Clutch Spring A $\Phi 29.6 \times \Phi 3 \times 31$	1	88280098	66	Stator	1
88224061	26	Washer B $\Phi 30.1 \times \Phi 35.4 \times 2$	1	88264066	67	Housing Ass'y	1
88210125	27	$\Phi 29.8 \times \Phi 1.5$ Retaining Ring	1	88264067	68	Dial Block	1
88275030	28	Impact Hammer	1	88244025	69	Switch	1
88264055	29	Fluorin O Ring $\Phi 10 \times \Phi 2$	1	88210129	70	Socket Connector	4
88275031	30	Impact Hammer Ferrule	1	88244023	71	Electricity Feels	1
88264051	31	Fluorin O Ring $\Phi 20 \times \Phi 2.5$	1	8.82E+08	72	0.22 μ F Electric Capacity	1
88264058	32	Buffering Washer $\Phi 18.1 \times \Phi 23.8 \times 5.6$	1	88244026	73	Carbon	2
88264053	33	Fluorin O Ring $\Phi 10.9 \times \Phi 3.6$	1	88244027	74	Carbon Brush Support Copper	2
88275032	34	Impact piston ferrule	1	88244028	75	Internal wiring	2
88224062	35	Steel Wire Block Ring $\Phi 23.5 \times \Phi 2$	1	88264068	76	Carbon Brush Support	2
88275033	36	Impact piston	1	88264069	77	Main Handle Cover	1
88264056	37	Fluorin O Ring $\Phi 16 \times \Phi 3$	1	88210115	78	Tapping Screw ST4.2x16	7
88290055	38	Gas Press Piston	1	88261010	79	Cord Clip	1
88224063	39	Washer C $\Phi 12.1 \times \Phi 18 \times 1$	2	88210076	80	Rivet	2
88264054	40	Fluorin O Ring $\Phi 3$	1	88264070	81	Cord Armor	1
88236008	41	Cuprum Group Bearing $\Phi 30 \times \Phi 34 \times 7.5$	1	88250000	82	Cord	1
88290056	42	Inner Cover	1	88264047	83	Side Handle Compages	1
88224064	43	Piston Pin $\Phi 12 \times 20$	1	88210110	83.1	Side Handle Bolt M8x90	1
88310006	44	Woolen Washer B	1	88290057	83.2	Side Handle Ass'y Base	1
88264060	45	Rubber Stopper	1	88264045	83.3	Side Handle	1
88310007	46	Woolen Washer C	1	88301020	84	Staff Guage	1
88224074	47	GearWheel Subassembly	1	88301007	85	Dual Screwdriver	1