

# XINPU

## Demolition Hammer

Model: *XP-G55B*

### HANDLING INSTRUCTIONS



#### Original Instructions

Before using this XINPU demolition hammer, please carefully read though these **HANDLING INSTRUCTIONS**. Ensure that you know how the machine works, and how it should be operated. Maintain the machine in accordance with the instructions, and make certain that the machine work correctly, please store this instriation and other enclosed documents with the machine together.



Bj:2012

Zhejiang Xinpu Industrial & Commercial Co., Ltd.

106, No. 330 National Road, Huajie Industrial Zone, Yongkang City, Zhejiang 321300, P. R. China

## list:

General Power Tool Safety Warnings  
Special Warning for Electric hammer  
Safety instructions  
Intended Use  
Technical Data  
Accessories  
Name of the parts  
Assembly  
Operation  
Maintenance and Service  
Warranty  
Environment

## General Power Tool Safety Warnings



### WARNING:

**Read all safety warnings and all instructions.** *Failure to follow all warnings and instructions may result in electric shock, fire and/or serious injury.*

**Save all warnings and instructions for future reference.**

The term “power tool” in the warnings refer to your mains operated (corded) power tool or battery operated (cordless) power tool.

#### 1) Work area

**a) Keep work area clean and well lit.** *Cluttered and dark areas invite accidents.*

**b) Do not operate power tools in explosive atmospheres, such as in the presence of flammable liquids, gases or dust.** *Power tools create sparks which may ignite the dust or fumes.*

**c) Keep children and bystanders away while operating a power tool.** *Distractions can cause you to lose control.*

#### 2) Electrical safety

**a) Power tool plugs must match the outlet. Never modify the plug in any way. Do not use any adapter plugs with earthed (grounded) power tools.** *Unmodified plugs and matching outlets will reduce risk of electric shock.*

**b) Avoid body contact with earthed or grounded surfaces such as pipes, radiators, ranges and refrigerators.** *There is an increased risk of electric shock if your body is earthed or grounded.*

**c) Do not expose power tools to rain or wet conditions.** *Water entering a power tool will increase the risk of electric shock.*

- d) **Do not abuse the cord. Never use the cord for carrying, pulling or unplugging the power tool. Keep cord away from heat, oil, sharp edges or moving parts. *Damaged or entangled cords increase the risk of electric shock.***
- e) **When operating a power tool outdoors, use an extension cord suitable for outdoor use. *Use of a cord suitable for outdoor use reduces the risk of electric shock.***
- f) **If operating a power tools in a damp location is unavoidable, use a residual current device (RCD) protected supply. *Use of an RCD reduces the risk of electric shock.***

### 3) Personal safety

- a) **Stay alert, watch what you are doing and use common sense when operating a power tool. Do not use a power tool while you are tired or under the influence of drugs, alcohol or medication. *A moment of inattention while operating power tools may result in serious personal injury.***
- b) **Use safety equipment. Always wear eye protection. *Safety equipment such as dust mask, non-skid safety shoes, hard hat, or hearing protection used for appropriate conditions will reduce personal injuries.***
- c) **Avoid accidental starting. Ensure the switch is in the off position before plugging in. *Carrying power tools with your finger on the switch or plugging in power tools that have the switch on invites accidents.***
- d) **Remove any adjusting key or wrench before turning the power tool on. *A wrench or a key left attached to a rotating part of the power tool may result in personal injury.***
- e) **Do not overreach. Keep proper footing and balance at all times. *This enables better control of the power tool in unexpected situations.***
- f) **Dress properly. Do not wear loose clothing or jewellery. Keep your hair, clothing and gloves away from moving parts. *Loose clothes, jewellery or long hair can be caught in moving parts.***
- g) **If devices are provided for the connection of dust extraction and collection facilities, ensure these are connected and properly used. *Use of these devices can reduce dust related hazards.***

### 4) Power tool use and care

- a) **Do not force the power tool. Use the correct power tool for your application. *The correct power tool will do the job better and safer at the rate for which it was designed.***
- b) **Do not (use the power tool if the switch does not turn it on and off. *Any power tool that cannot be controlled with the switch is dangerous and must be repaired.***

- c) **Disconnect the plug from the power source before making any adjustments, changing accessories, or storing power tools.** *Such preventive safety measures reduce the risk of starting the power tool accidentally.*
- d) **Store idle power tools out of the reach of children and do not allow persons unfamiliar with the power tool or these instructions to operate the power tool.** *Power tools are dangerous in the hands of untrained users.*
- e) **Maintain power tools. Check for misalignment or binding of moving parts, breakage of parts and any other condition that may affect the power tools operation. If damaged, have the power tool repaired before use.** *Many accidents are caused by poorly maintained power tools.*
- f) **Keep cutting tools sharp and clean.** *Properly maintained cutting tools with sharp cutting edges are less likely to bind and are easier to control;*
- g) **Use the power tool, accessories and tool bits etc., in accordance with these instructions and in the manner intended for the particular type of power tool, taking into account the working conditions and the work to be performed.** *Use of the power tool for operations different from intended could result in a hazardous situation.*

## 5) Service

- a) **Have your power tool serviced by a qualified repair person using only identical replacement parts.** *This will ensure that the safety of the power tool is maintained.*

## Special Warning for Electric hammer

- **Wear ear protection.** *Exposure to noise can cause hearing loss.*
- **Use auxiliary handle with the tool.** *Loss of control can cause personal injury.*
- **Hold Power tool by insulated gripping surfaces, when performing an operation where the cutting accessory may contact hidden wiring or its own cord.** *Cutting accessory contacting a “live” wire may make exposed metal parts of the power tool “live” and could give the operator an electric shock.*
- **Wear a dust mask.**

## Power Tool-specific Safety Rules

- ▶ **When working with the power tool, always hold it firmly with both hands and provide for a secure stance.** The power tool is guided more secure with both hands.
- ▶ **Secure the workpiece.** A workpiece clamped with clamping devices or in a vice is held more secure than by hand.
- ▶ **Do not work materials containing asbestos.** Asbestos is considered carcinogenic.
- ▶ **Take protective measures when dust can develop during working that is harmful to one’s health, combustible or explosive.** Example: Some dusts are regarded as carcinogenic. Wear a dust mask and work with dust/chip extraction when connectable.

- ▶ **Always wait until the power tool has come to a complete stop before placing it down.** The tool insert can jam and lead to loss of control over the power tool.
- ▶ **Do not use the power tool with a damaged cord. Do not touch the damaged cord and pull the plug from the outlet when the cord is damaged while working.** Damaged cords increase the risk of an electric shock.
- ▶ **Connect power tools that are used in the open via a Ground Fault Circuit Interrupter (GFCL).**
- ▶ **Ear hearing protection.** Exposure to noise can cause hearing loss.
- ▶ **Use the auxiliary handle supplied with the power tool.** Loss of control over the power tool can cause personal injury.
- ▶ **Use suitable detectors to determine if utility lines are hidden in the work area or call the local utility company for assistance.** Contact with electric lines can lead to fire and electric shock. Damaging a gas line can lead to explosion. Penetrating a water line causes property damage or may cause an electric shock.
- ▶ **Hold the power tool only by the insulated gripping surfaces when performing an operation where the cutting tool may contact hidden wiring or its own power cord.** Contact with a “live” wire will also make exposed metal parts of the power tool “live” and shock the operator.
- ▶ In case of damages the replacement of the plug or the supply cord shall always be carried out by the manufacturer of the tool or his service organization

### **Residual risks**

**Even when the power tool is used as prescribed it is not possible to eliminate all residual risk factors. The following hazards may arise in connection with the power tool's construction and design:**

- a) Injuries and damage to property due to broken accessories that are suddenly dashed.
- b) Health defects resulting from vibration emission if the power tool is being used over longer period of time or not adequately managed and properly maintained.
- c) Lung damage if don't use dust mask.
- d) Hearing damage if don't use ear protection.

 **Warning!** This power tool produces an electromagnetic field during operation. This field may under some circumstances interfere with active or passive medical implants. To reduce the risk of serious or fatal injury, we recommend persons with medical implants to consult their physician and the medical implant manufacturer before operating this power tool.

# Safety instructions

In this operator's manual/or machine's labels following symbols are used:



Accordance with essential applicable safety of European directives



Double insulation



Denote risk of personal injury, loss of life or damage to the tool in case of nonobservance of the instruction in this manual.



Indicate electrical shock hazard.



Immediately unplug the plug from the main electricity in the case that the cord gets damage and during maintenance.



Wear ear and eye protection.



**Read all safety warnings and all instructions.** Failure to follow the warnings and instructions may result in electric shock, fire and/or serious injury.



Waste electrical products should not be disposed of with house hold waste, Please recycle where facilities exist. Check with your local Authority or retailer for recycling advice.

---

## Intended Use

---

The power tool is intended for chiseling work in concrete, brick, masonry and asphalt as well as for driving in and compacting, when using the respective accessories.

---

## SPECIFICATIONS

---

### Technical Data

<b>Demolition Hammer</b>	<b>XP-G55B</b>
<b>Rated Voltage</b>	<b>220-240V</b>
<b>Frequency</b>	<b>50Hz</b>
<b>Rated input</b>	<b>1500W</b>
<b>Impact frequency</b>	<b>1000-1900 min<sup>-1</sup></b>
<b>Impact energy per stroke</b>	<b>6-25J</b>
<b>Chisel positions</b>	<b>12</b>
<b>Chiselling capacity in concrete of medium hardness</b>	<b>490kg/h</b>
<b>Tool holder</b>	<b>SDS-max</b>
<b>Lubrication</b>	<b>Central permanent lubrication</b>
<b>Weight</b>	<b>10.5kg</b>
<b>Sound pressure values (in accordance with 2000/14/EC)</b>	101. 58dB (A)
<b>Guaranteed Sound power values (in accordance with 2000/14/EC)</b>	105dB (A)
<b>Vibration</b>	<b>Main handle: <math>a_{h,Cheq} : 16.978 \text{ m/s}^2</math> <math>k=1.5\text{m/s}^2</math></b> <b>Auxiliaryhandle: <math>a_{h,Cheq} : 15.940\text{m/s}^2</math> <math>k=1.5\text{m/s}^2</math></b>
<b>Protection class</b>	<b>II</b>

The values given are valid for nominal voltages [U] of 220-240V. For lower voltages and models for specific countries, these values can vary.

**Hinweis:** Die Schall- und Vibrationswerte wurden gemessen gemäß EN 60745-1 und EN 60745-2-6.

**Hinweis:** Der angegebene Vibrationswert ist nach einem genormten Prüfverfahren ermittelt worden und kann verwendet werden, um verschiedene Elektrowerkzeuge miteinander zu vergleichen. Zudem eignet sich dieser Wert, um Belastungen für den Benutzer, die durch Vibrationen entstehen, im Vorhinein einschätzen zu können.



**Warnung!** Abhängig davon, wie Sie das Elektrowerkzeug einsetzen, können die tatsächlichen Vibrationswerte von dem angegebenen abweichen.

Ergreifen Sie Maßnahmen, um sich gegen Vibrationsbelastungen zu schützen. Berücksichtigen Sie dabei den gesamten Arbeitsablauf, also auch Zeitpunkte, zu denen das Elektrowerkzeug ohne Last arbeitet oder ausgeschaltet ist.

Geeignete Maßnahmen umfassen unter anderem eine regelmäßige Wartung und Pflege des Elektrowerkzeuges und der Werkzeugaufsätze, Warmhalten der Hände, regelmäßige Pausen sowie eine gute Planung der Arbeitsabläufe.

## Standard accessories

Hexagon bar wrench 10mm	1 piece
Amphibious screwdriver	1 piece
One bottle of grease	60g
Bull point chisel (18×400mm)	1 piece
flat chisel (18×400mm)	1 piece
Carbon brush ((6.5×17×26) mm)	1 couple

---

## OPTIONAL ACCESSORIES (sold separately)

---

1. Tine Chisel: 18\*400mm (SDS max )

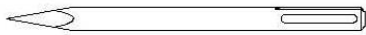

2. Flat Chisel : 18\*400mm (SDS max )

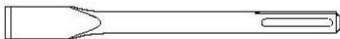

3. Big Flat Chisel : 18\*400mm (SDS max )

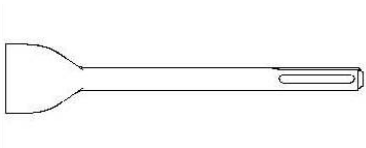

4. Goose Chisel :18\*400mm (SDS max )



5. Surface Roughing (Hammering)

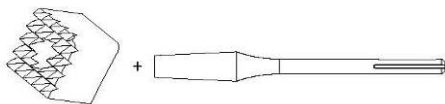

(1) Bushing Tool

(2) Shank

6. Tamping (Hammering)

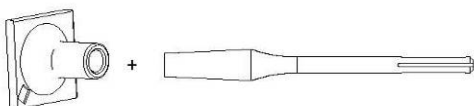

(1) Rammer

(2) Shank (150 x 150 mm)

Optional accessories are subject to change without notice.



---

## Name of the parts

---

1. Hammer rod protector
2. Protective lining
3. Move limited ring
4. Switch Push-And-Pull
5. Speed Adjuster Function Knob
6. Indicator
7. Side Handle
8. Function Knob

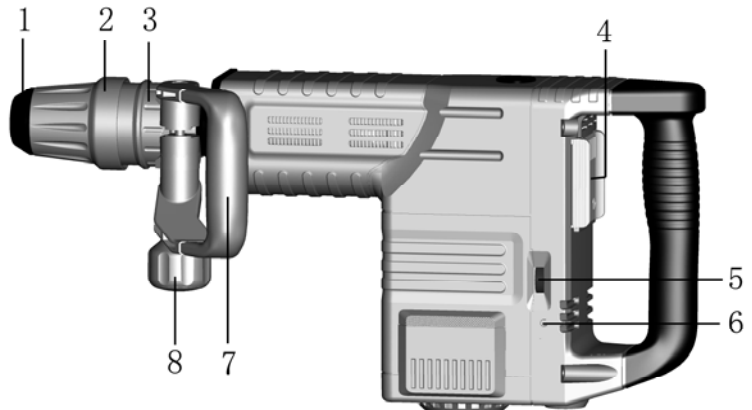

---

## Assembly

---

### Auxiliary Handle

**Operate your power tool only with the Side Handle 7.**

The Side Handle 7 can be set to any position for a secure and low-fatigue working posture.

Loosen the Function Knob 8, rotate the Side Handle 7 around the axis of the power tool to the required position and tighten the Function Knob 8 again.

The Side Handle 7 can be mounted to a different position. For this, completely unscrew the Function Knob 8 and then pull out the hexagon bolt upward. Pull off the Side Handle 7 to the side and turn around the remaining clamping element by 180°. Mount the Side Handle 7 in reverse order.

---

### Changing the tool

---

**Before any work on the power tool itself, pull the mains plug.**

With the SDS-max tool holder. Simpler and easier tool changing is possible without additional aids.

The Hammer rod protector 1 largely prevents the entry of drilling dust into the tool holder during operation. When inserting the tool, take care that the Hammer rod protector 1 is not damaged.

**A damaged Hammer rod protector should be changed immediately.** We recommend having this carried out by an after-sales service.

#### Inserting (see figure A)

Clean and lightly grease the shank end of the tool.

Insert the tool in a twisting manner into the tool holder until it latches itself.

Check the latching by pulling the tool.

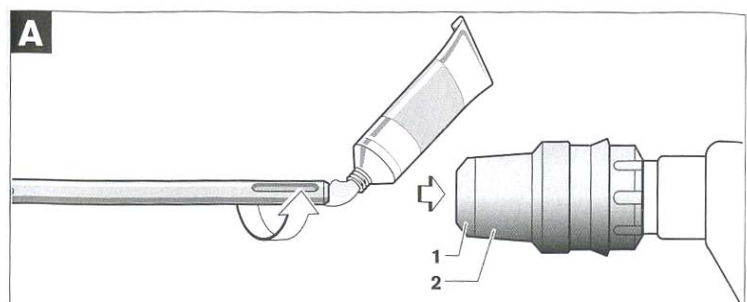

#### Removing (see figure B)

Push back the Protective lining 2 and remove the tool.

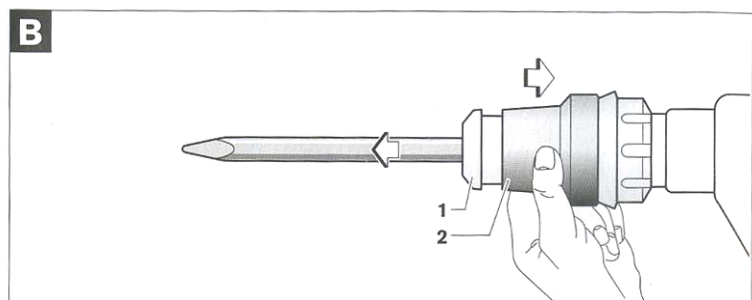

# Operation

---

## Starting Operation

---

**Observe correct mains voltage!** The voltage of the power source must agree with the voltage specified on the type plate of the power tool.

### Switch On and Off

**To start the power tool, push the Switch Push-And-Pull to the right.**

**To Switch off the power tool, push the Switch Push-And-Pull to the left.**

For low temperatures, the power tool reaches the full impact rate only after a certain time.

This start-up time can be shortened by striking the chisel in the power tool against the floor one time.

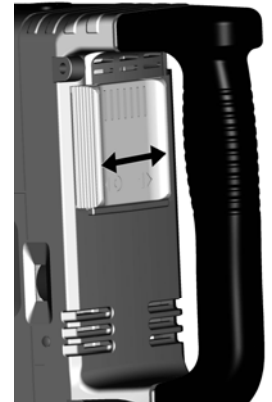

### Setting the Impact Rate

The electronic control enables stepless speed preselection in accordance with the material to be worked. The constant electronic control keeps the preselected impact rate nearly constant between no-load and load conditions.

Select the impact rate with the Speed Adjuster Function Knob 5 according to the material.

The data in the following table are recommended values.

Speed Adjuster Function Knob 5	Impact frequency( $\text{min}^{-1}$ )
1	1000
2	1200
3	1350
4	1550
5	1750
6	1900

### Changing the Chiselling Position (Vario-lock)

The chisel can be locked in 12 positions. In this manner, the optimum working position can be set for each application.

Insert the chisel into the tool holder.

Push the Move limited ring 3 forward and turn the chisel to the required position with the Move limited ring 3.

Release the Move limited ring 3 and turn the chisel until it latches.

# Maintenance and Service

---

## Maintenance and cleaning

---

**Before any work on the power tool itself, pull the mains plug.**

**For safe and proper working, always keep the power tool and the ventilation slots clean.**

A **damaged** hammer rod protector should be changed immediately. We recommend having this carried out by an after-sales service.

### **Indicator 6**

When the carbon brushes are worn out, the power tool switches itself off. This is indicated approx. **8** hours beforehand by the lighting or blinking of the indicator **6**. The power tool must then be sent to an after-sales service agent.

If the power tool should fail despite the care taken in manufacturing and testing procedures, repair should be carried out by an after-sales service center for XINPU power tools.

---

## Warranty

---

For the condition of warranty, please refer to the separately provided warranty card.

---

## Environment

---



Faulty and /or discarded electrical or electronic apparatus have to be collected at the appropriate recycling location.

# XP-G55B Hammer Part Chart

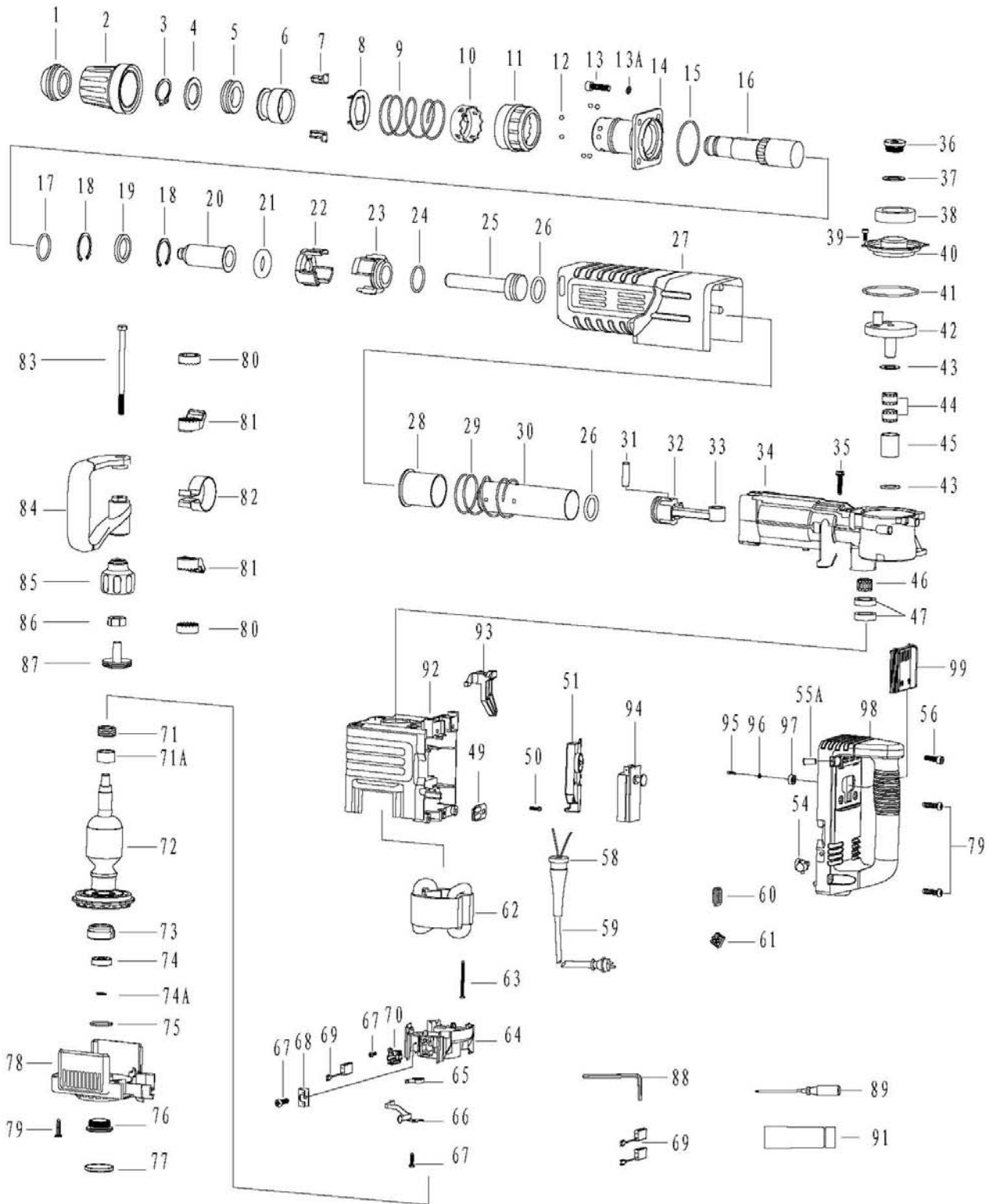

## XP-G55B Hammer Parts List

XP-No	Item No.	Part Describe	Quantity	XP-No	Item No.	Part Describe	Quantity
88263081	1	Hammer rod protector	1	88210132	50	ST4.2×22 Tapping Screw	1
88263060	2	Protective lining	1	88243020	51	Speed Adjuster TSQ 03	1
88211046	3	Φ30 Retaining Ring	1	88263069	54	Indicator	1
88223031	4	Support patch	1	88320058	55A	Screws Ring	2
88263082	5	Shock absorption ring	1	88210195	56	Hex. Socket Bolt M6×30 (12.9)	2
88273025	6	Move limited ring	1	88263071	58	Cord Armor	1
88223032	7	Insert block	2	88250000	59	Cord	1
88223033	8	Change plate	1	88243023	60	0.18μH Electricity Feels	1
88223034	9	Support ring spring	1	88210076	61	Rivet	1
88223035	10	Support ring	1	88280095	62	Stator 220-240V	1
88263061	11	Move limited ring	1	88210042	63	ST4.8×58 Tapping Screw	2
88210122	12	Φ6.5 Steel Ball	8	88263072	64	Carbon Brush bracket	1
88210016	13	Hex. Socket Bolt M8×30(12.9)	4	88223046	65	Helical spring	2
88210053	13A	Φ8 Spring Washer	4	88223047	66	Metal contact plate	1
88273026	14	Flange cover	1	88210118	67	Tapping screw ST3.5×16	5
88263083	15	O-RingΦ63.5×Φ2.6	1	88223048	68	Metal insert	2
88223036	16	Hammer rod sleeve	1	88243027	69	Carbon Brush	2
88263084	17	O-RingΦ31.6×Φ2.5	1	88223049	70	Carbon brush wire	2
88210123	18	Φ41 Retaining Ring	2	88273031	71	Screw seal ring	1
88263085	19	Oil Seal Ring Φ32×Φ42×7	1	88223054	71A	Armature sleeve	1
88273027	20	Impact Pin	1	88280096	72	Armature 220-240V	1
88263086	21	Fluorin O RingΦ22×Φ11	1	88223050	73	Bearing Sleeve	1
88263062	22	Control plate	1	88236011	74	6200 2RS Ball Bearing	1
88263063	23	Fixed Distance Sleeve	1	88210092	74A	Φ10 Retaining Ring	1
88263087	24	O-RingΦ35×Φ3	1	88263090	75	O-Ring Φ30×Φ2	1
88273028	25	Impact block	1	88223051	76	Screw ring	1
88263088	26	Fluorin O RingΦ30.4×Φ5	2	88263073	77	Protected cover	1
88263064	27	Cover	1	88263074	78	Bearing Cover	1
88223037	28	Control Sleeve	1	88210119	79	Tapping screw ST5.5×25	8
88223038	29	Control Sleeve Spring	1	88263075	80	Disk with gap	2
88273029	30	Cylinder	1	88263076	81	Clamping	2
88223039	31	Piston Pin Φ10×38	1	88223052	82	Fixed belt	1
88263065	32	Piston	1	88210121	83	Hexagon head bolt M8×130	1
88263066	33	Connecting Rod Ass'y	1	88263077	84	Side Handle	1
88290054	34	Impact body	1	88263078	85	Function Knob	1
88210116	35	Tapping screw ST6.3×32	4	88320045	86	Nut M8(Thickness 6.4mm)	1
88223055	36	Oil Tank Cover	1	88263079	87	Function Knob cover	1
88263126	37	Rubber Washer	1	88301022	88	10mm Hex Bar Wrench	1
88310003	38	Felt Ring	1	88301007	89	Dual Screw Driver	1
88210002	39	Hex .Socket BoltM5×12	4	88304020	91	Oil BottleΦ35×135	1
88223040	40	Shell cover	1	88263091	92	Housing Ass'y	1
88263089	41	O-Ring Φ79×Φ2.8	1	88263092	93	Dial Staff Sheath	1
88273032	42	Eccentric gear subassembl	1	88243025	94	Switch	1
88223042	43	Boring washer	2	88210142	95	ST3.5x8 Tapping Screw	1
88234014	44	Needle Bearing RMAO16×22×1	2	88210054	96	Φ4 Flat Washer	1
88223043	45	Needle Ferrule	1	88231019	97	606 RZ Ball Bearing	1
88234015	46	Needle Bearing NK20×28×13	1	88263093	98	Handle	1
88223053	47	Seal ring subassembly	2	88263094	99	Switch Push-And-Pull	1
88223045	49	Cord Clip	1				